



STANDARDIZED NODES

MILLING HEADSTOCK VFS 630 A

The VFS 630 A milling headstock is a basic standardized node designed for the construction of single purpose machining equipment. The headstock, positioned crosswise on the table of given slide unit, forms a ram milling unit JIFS 630 A, which enables heavy milling and similar operations.

Basic work cycle of unit JIFS 630 A: feel, rapid traverse, work feed, set off, rapid traverse back.

Description of basic version

The milling headstock consists of the following groups: headstock, spindle actuator box, rail. The spindle actuator box and feed box are fitted with Siemens regulating electric motors. The headstock rail is fitted by hydraulic firming. By standard, the headstock is not fitted by the inner feed of cutting liquid.

Work position

The standard version of the headstock may only work in horizontal position.

Alternative version

- electrical motors by other manufacturers
- Inner feed of cutting fluid

Technical parameters of basic version

Travel of headstock ram [mm]	200
Max. feed speed [min^{-1}]	7,5
Maximum axis force [kN]	15
Max. spindle speed [min^{-1}]	300 (alt. more)
Gear ratio between motor and spindle	1:15 (alt. other)
Max. spindle torque up to $n=100 \text{ min}^{-1}$ [Nm]	4100/6510 (S1/S6-40%)
Max. output of electrical motor [kW]	51/81 (S1/S6-40%)
Spindle diameter in front bearing [mm]	160
Rated hydraulic pressure for firming of rail [MPa]	6
Headstock weight [kg]	Approx. 2600

- *The detailed data is not binding with respect to ongoing development; the basic version can be adapted according to customer requirements.*

Output and torque parameters of spindle

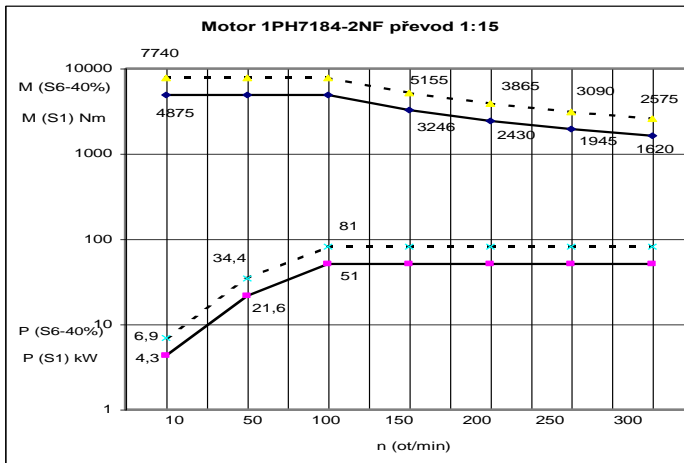

Dimension draft

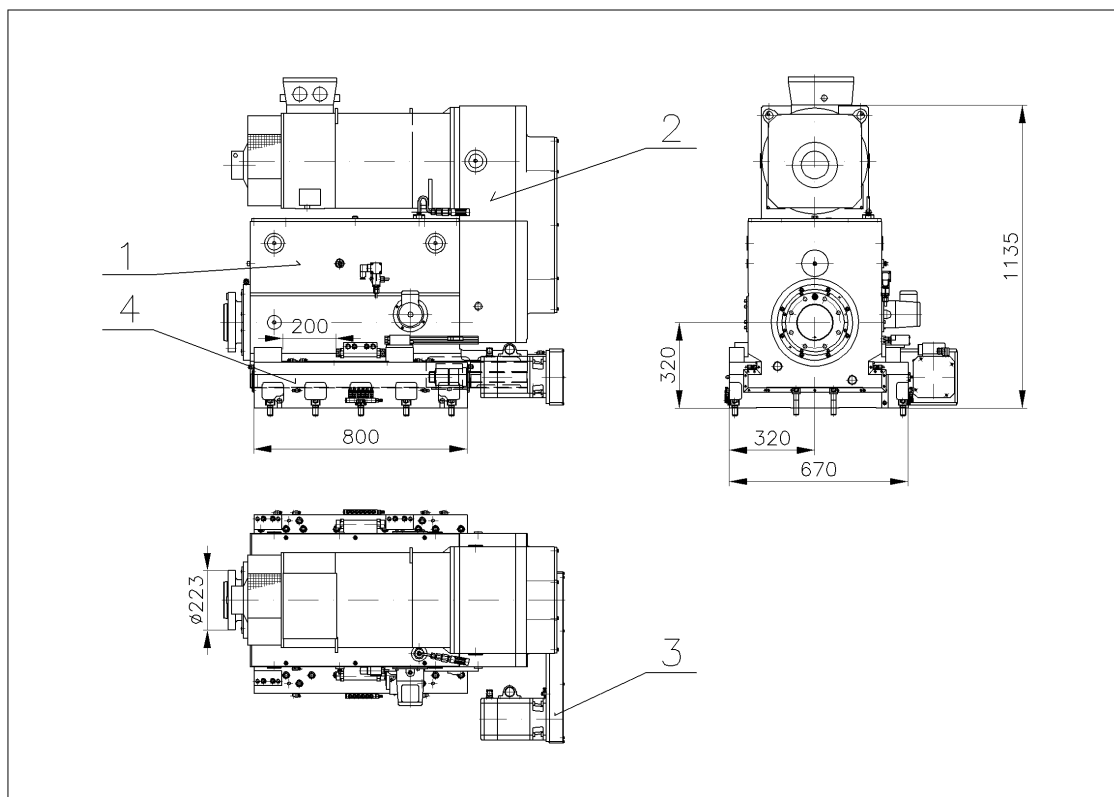

1...headstock
2...actuator box of spindle

3...feed box
4...rail

- *The detailed data is not binding with respect to ongoing development; the basic version can be adapted according to customer requirements.*